

# POWER YOUR FUTURE

## Weichai Generator LG520WP

# 6M33D633E200

Prime Power: 520KW/650KVA

Standby Power: 570KW/715KVA



## GENERATING POWER SOLUTIONS

### Increased availability for new operations

Reliable, robust and versatile generator.  
Ready to deliver power for a next job.

### Increased uptime during operations

Once installed on the end-user-site, the generator will be ready to run: "peace of mind" operation.

### Reduced transport and installation costs

The compact and robust design with integrated transport features enables faster and safer transport and installation.

### Reduced service & maintenance costs

Longer service intervals.  
Quicker and more efficient service jobs.

### Premium resale value

Designed and built to last.

### SAFETY

- Operate safely in accordance with proper operation manual.
- To prevent trouble and accidents, perform daily and preventive maintenance checks without fail.

## Weichai Baudouin Series 500KVA--42000KVA



## FUAN LONGKAI POWER CO.,LTD.

Headquarters:

Add: Wei 5 Road, Tiehu Industrial Zone, Fuan, Fujian, China

Tel: +86-0593-6309773 Fax: +86-0593-6586988

E-mail: [sales@longkaipower.com](mailto:sales@longkaipower.com)

Web: [www.longkaipower.com](http://www.longkaipower.com)

## Technical Data

LG520WP

Model		LG520WP
Rated prime power	kva	650
Rated standard power	kva	715
Rated voltage line to line	V	400/230
Rated current	A	938
Maximun sound level	dB(@7m)	≤102

### Engine-Weichai

Model	6M33D633E200	
Aspiration	Turbocharging and intercooling	
Fuel system	Mechanical Pump+Electronic Speed Governor	
No. cylinders	V 12	
Displacement	Liquid	18.9
Bore*Stroke	mm	159*159
Compression ratio	15:01	
Rated speed	r/min	1500
Rated net power(with fan)	Kw	575
Governor type	EFC Electrical	
Start Motor	V	24

### Exhaust System

Exhaust gas flow	L/s	3266.8
Exhaust gas temp	°C	550
Max back pressure	kPa	7.5

### Aspiration System

Max inlet pressure	kPa	≤3
Allow intake resistance	kPa	/
Air flow	L/s	3150

### Fuel System

100% load(Prime power)	L/h	136.0
75% load(Prime power)	L/h	/
50% load(Prime power)	L/h	/
Fuel tank capacity	L	1200
	(External Fuel Tank)	

### Lubrication System

Oil capacity	L	61
Oil consumption	g/kwh	0.3
Oil pressure	kPa	400-650
	(continuous operation)	

### Cooling System

Coolant capacity	L	43.9
Thermostat operation range	°C	80-92
Max water temperature	°C	95

### Alternator

Model	LONGKAI	LK544F
	STAMFORD	HCI544F-S5L1D-F4/S5L1S-F4
Phase	3	
Voltage	V	400/230
Wiring Type	3 Phase 4 wire, Y type	
Bearing	1	
Power factor	0.8	
Frequency	Hz	50
Prime power	KW	536
Exciter Type	Brushless, self-excitation	
Voltage regulation	%	±0.5
Protection Grade	IP 23	
Insulation grade	H/H	
Altitude	m	≤1000

### Controller-DEEPSEA

Model	DSE6120MK3
-------	------------

Protective functions:

- Low oil pressure
- High water temperature
- High/low voltage
- High Engine Temperature and Overspeed.
- Voltage regulator frequency regulator
- Emergency stop
- Start failure



### Control Module Options



- Auto generator control module
- Control module with "Three Remote Control" functions
- ATS auto load transfer screen
- Synchronising control modules
- Power output cabinet

### Standard Features

- Engine(Weichai Baudouin)
- Radiator 50°C max,fans are driven by bel
- 24V charge alternator
- Alternator: single bearing alternator IP23, insulation class H/H
- Standard auto control system
- One set of air filter, fuel filter, oil filter
- Main line circuit breaker/MCCB
- Base fuel tank
- Two 24V batteries, rac and cable
- Exhaust system(Ripple flex exhaust pipe, exhaust siphon, flange, muffler)
- User manual

### Options

- Battery charge
  - Engine heater
  - Alternator heater
  - PMG
  - Water oil separator
  - Daily fuel tank
  - Remote control panel
  - Automatic transfer switch/ATS
  - Switch box
- Standard: ●                      Options:○

### Warranty\*

#### Weichai Engine

12 months from date of purchase and 1000 hours.

#### Generator

12 months from date of purchase or 1000 hours (whichever occurs first).

### Unit Dimensions(Basic unit)

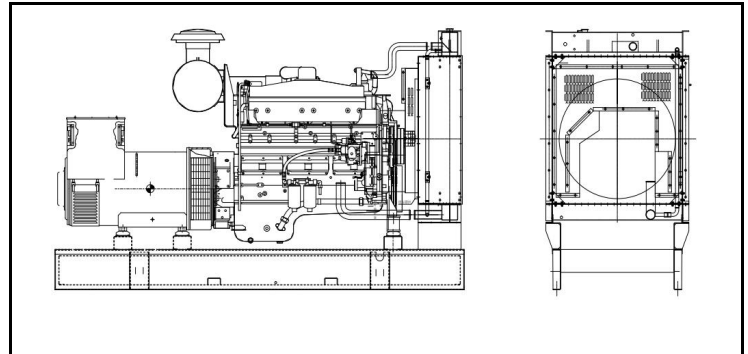

<b>Open Type</b>		
L*W*H	mm	3800*1600*2200
Weight	kg	4100

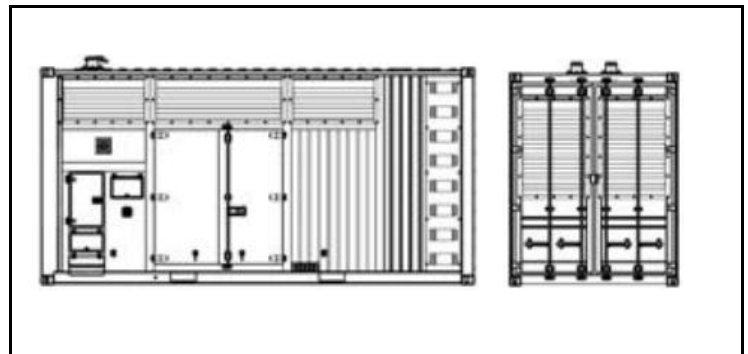

<b>Silent Type(Standard 20'ft container)</b>		
L*W*H	mm	5170*1970*2500
Weight	kg	5200